

# ***BEAM SPOT WASH 3IN1 HEAD***

## **USERS GUIDE**

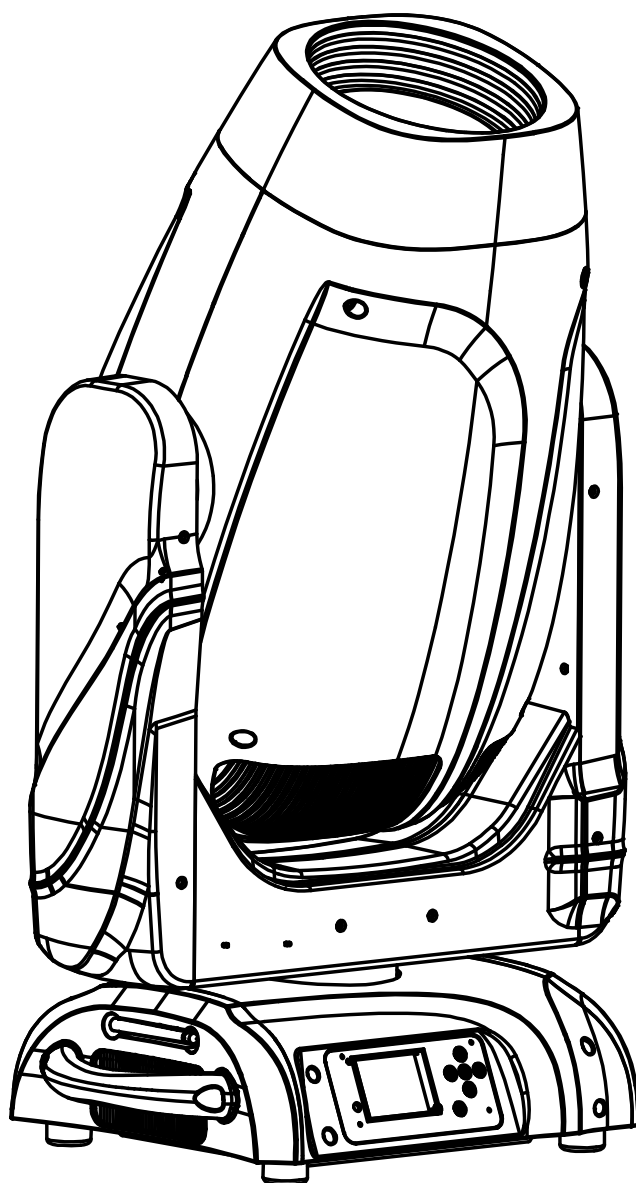

CE

## 1. Product Introduction:

1.1 Before unpack the fixture, pls make sure that the packing is in good condition, following items will be found in the box:

- The fixture
- This users guide
- 3m DMX cable
- 1.5m power cable with powercon
- Omega bracket for hanging installation
- Safety chain

## 1.2 Specification

### Source

- Light source: Advanced 640w white led
- Led life: 20.000 hours
- Luminous Flux: 83800 lux@5m
- Control: Remote on/off via DMX
- Ballast: switching mode power supply

### Optical System

- Beam angle: 4° to 50 °

### X/Y

- Pan: 540°(4.7 sec),Tilt: 267° (4 sec)
- 16-bit resolution
- Auto repositioning

### Colors

- Linear CMY+CTO
- 8+open, interchangeable, indexable and bidirectional rainbow effect
- Color bounce

### Gobos

- Outside  $\varnothing$  30mm, inside  $\varnothing$  20mm
- 7+open custom interchangeable position for rotating gobo wheel
- 8+open fixed gobos
- Real indexable and gobo shaking
- Distinctive gobo animation effect

## Features

- DMX channels: 39
- Linear CMY+CTO
- Motorized focus
- Full range 0-100% dimmer
- Various strobe
- Rotating 4 facets prism
- Frost
- Fast speed iris
- Beam from 4° to 50 °
- 4 individually positionable Shutter blades rotating +/- 45°
- RDM function to change DMX address, display flip, X/Y Reverse and so on
- RDM read voltage,current,power consumption of lamp
- Software upgrade via DMX or USB
- Hibernation when lost DMX for preset time
- Indicate temperature info of base, arm
- Fan speed auto change according to temperature

## Display

- 2.4inch super nice LCD display
- Auto lock and flip

## Power

- Max power consumption: 866W
- Powercon in , 3+5 pins DMX
- Power supply: Electronic auto-ranging
- Input voltage range: 100–240V, 50-60Hz

### 1.3 Description of the Device

1. Project lens
2. Head
3. Arm
4. Base
5. Display
6. Foot stand
7. Operation button
8. Handel

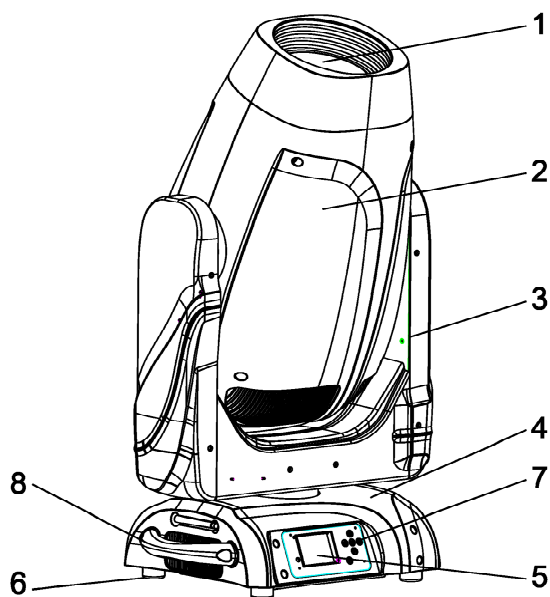

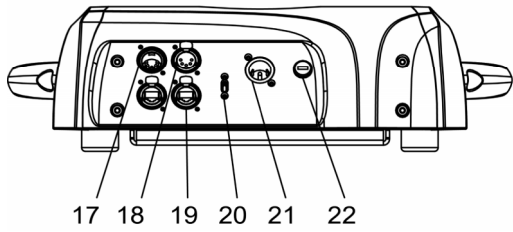
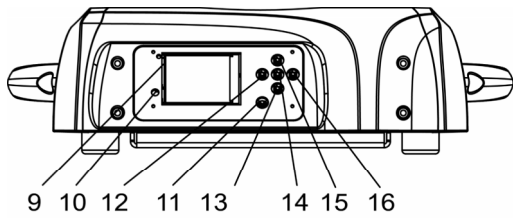

- 9. Wireless indicator
- 10. Ethernet
- 11. Battery indicator
- 12. Left button
- 13. Down button
- 14. Enter button
- 15. Up button
- 16. Right button
- 17. 5-pin DMX in
- 18. 5-pin DMX out
- 19.ETHERNET
- 20.USB
- 21. Power in
- 22.Fuse











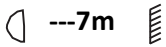

#### 1.4 Colors and Gobos

		Open	
	1	Color temperature correction	
	2	red	
	3	green	
	4	blue	
	5	Pale yellow	
	6	Pink	
	7	Orange red	
	8	CRI-17	



## 2. Safety and maintenance Information

### 2.1 Safety Info

	Before operate this unit, please carefully read this users guide and keep if needed in future. It's necessary to respect following rules.
	The disposal of the device after lifecycle could damage the environment, need to take it to special company for recycling or return to authorized dealer.
	The products referred to in this manual conform to the European Community Directives and are therefore marked with CE logo.
	Keep this device away from children and unauthorized users, the manufacturer will not take responsibility for the damage due to any disregard of the information provided in this manual and wrong operation.
	Before operate the device, pls make sure the fixture is in good housing, ensure pan and tilt can rotate in its complete range.
	Pls make sure minimal 7m distance need to kept between the fixture to any flammable material.
	The device can only run with 100-240v voltage, 50/60Hz power, don't connect to any other wrong power. Disconnect the device from main power before open the shield or maintenance.
<b>IP 65</b>	For outdoor events.
	Never look directly into the projecting lens when the fixture is power on, the light may trigger epileptic seizures in photosensitive persons or persons with epilepsy. Especially at beam effect, extreme caution and observance of these safety instructions is mandatory.
	Don't put or install the device on a surface that subject to vibration or bumps.
<b>Ta=45°C</b>	The device is supposed to work in the temperate range -15°C t o +45°C, do not use the device when the temperate exceed this range.
	The lens, shield need to be replaced when obviously broken, never use the device when the shield is not completed closed.
	Safety I class device, need to be earth connected.
	When the fixture is hanged overhead, the safety rope must be fixed to the bottom of the device to the appropriate fixing point.
	Always carry the device by the handles, do not take the head or arm directly for transportation.

### 2.2 Maintenance

2.2.1 Operation only allowed to qualified person, damages due to unprofessional operation or remove of any parts inside will not be considered in warranty service. There are no serviceable parts inside the device or package, service only leaves to authorized dealers.

2.2.3 Never allow the optical components contact with oil, fat or any other liquid.

2.2.4 A regular clearance of the device is needed for long-term usage, this is very helpful to maintain the lifetime and brightness need to use a soft and lint-free cloth to clean the optical system, fan and air flowing tunnel.

### 2.2.5. Trouble Shooting

Problems	Possible reasons	Checking or solutions
Device not power up	Powercon or power cable damaged Faulty power supply	Change a good power cable to try Replace new power supply
Pan/Tilt error or vibrate	Faulty Pan/Tilt PCB Faulty opto sensor Cable loosen	Replace PT013 PCB Replace opto sensor OP005 Check the cable connect to OP005
Lamp off	Temperature protection Fan not working Faulty Lamp Dimmer and strobe set at 0 Faulty power supply	Check the temperature from menu Check the fan speed info from menu Replace new Lamp Set dimmer and strobe channel at 255 Replace new power supply
Device not response to DMX	Faulty display PCB Wrong DMX addressing Faulty DMX cable	Replace new display PCB Check the address and setting Change to a good DMX cable

### 2.2.6 Replacement of the fuse

Need to replace with same type and rating, which originally installed in the device.

Step One: Unplug power cable from main power.

Step Two: Unscrew the fuse holder out of the housing with a screwdriver.

Step Three: Remove the broken fuse and replace with an exact same type of new fuse.

Step Four: Insert the fuse holder back to the housing and screw tight and reconnect power.

### 3. Installation

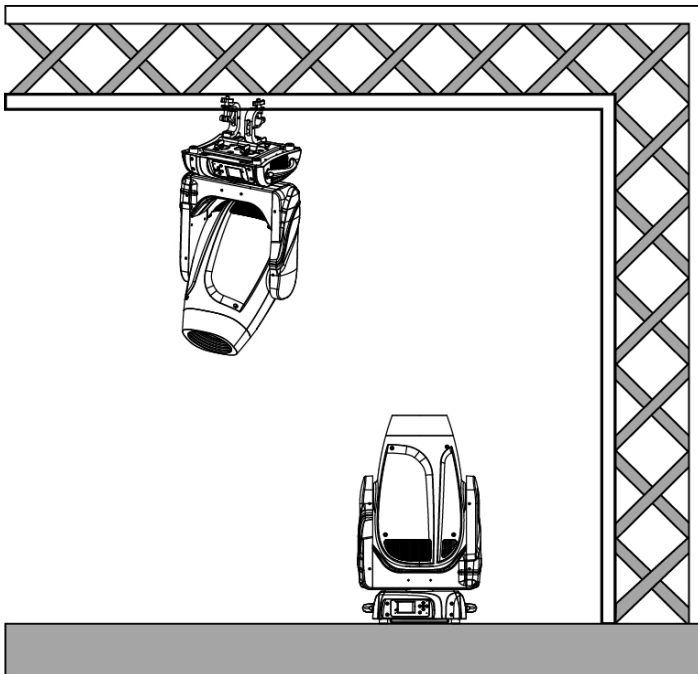

3.1 The device could be either put on a solid and even surface, or mounted upside down or sideways like left picture.

3.2 The mounting place must be sufficient stable and be able to support a weight of 10 times of the unit's weight. When the fixture is hanged, always additionally secure the device with the safety chain, fasten the safety rope at a suitable position so that the maximum fall of the projector will be 20 cm

### 3.3 How to do mounting installation.

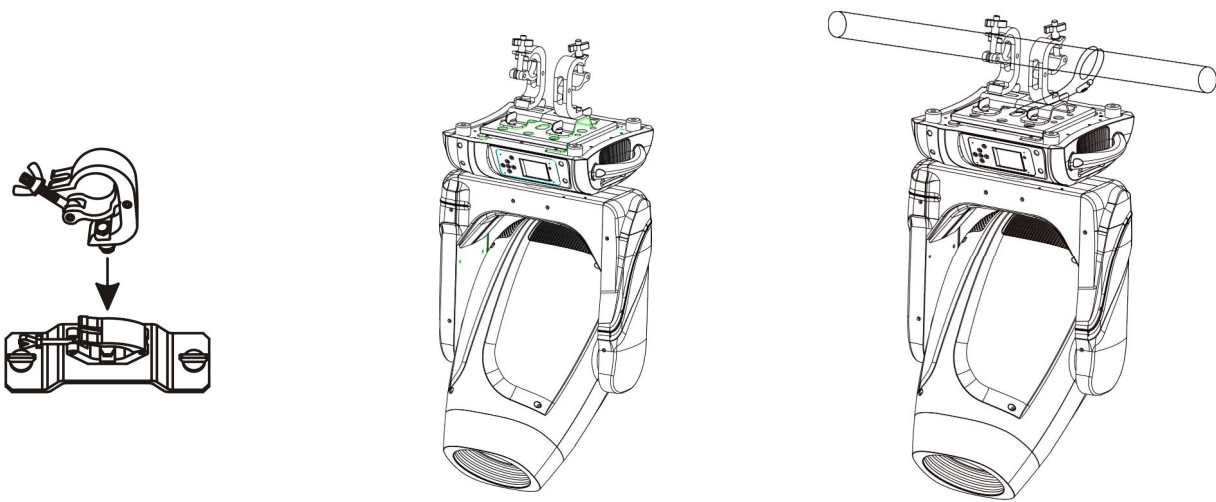

Step one: Installation the clamp onto the omega bracket;

Step two: Install the clamp and bracket on the bottom of panel, fasten the quick-locks;

Step three: Install the whole device onto appropriate truss and fasten the clamps, tight the safety rope with the truss or other fixing point at a suitable position that drop down distance not exceed 20 cm.

## 4. Control menu

### 4.1 Meaning of the icon in menu

CONNECT	LIGHT	INFOMATION	SET	PROGRAM
				

### 4.2 Menu tree

Default setting shadowed. mark with ① can be basic reloaded, ② be program reloaded, ③ can be private reloaded.

Connet	Address①	Value (1-512)			
	Control protocol	DMX/W-DMX/sACN/Artnet			
	DMX Mode	Standard/Extended			
	Wireless	WDMX On/Off	On/Off		
		WDMX Mode	Transmitter/Receiver		
		TX Link	On/Off		
		TX Unlink	On/Off		
		RX Reset	On/Off		
		DMX To WDMX (TX)	On/Off		
		WDMX To DMX (RX)	On/Off		
	Ethernet Setting	Artnet Settings	IP Address	2.xxx.xxx.xxx	
			Net	xxxxxx	
			Subnet	xxxxxx	
			Universe	xxxxxx	
		sACN Settings	IP Address	2.xxx.xxx.xxx	
Universe			xxxxxx		

			Merge Mode	Off/Htp/Ltp
		Ethernet To DMX	On/Off(On)	
Setup	Fixture Settings	Dmx Fault①	Hold/Blackout(Hold)	
		Temperature Unit	Fahrenheit /Celsius(Celsius)	
		Hibernation	Off, 01M~99M	
		Fan Mode	AUTO/HIGH/SILENT(AUTO)	
		Dimmer Curve	LINEAR/S-CURVE/SQUARE LAW/ INVERSE SQUARE LAW	
		Dimmer Speed	AUTO/FAST/MEDIUM/SLOW	
		LED Frequency	600HZ/1200 HZ/2000 HZ/4000 HZ/6000HZ/25KHZ/50KHz	
		Menu Language	En/Fr/Sp/简/繁 (En)	
		Transfer Configuration	No Dmx Address With Dmx Address	
	Movement	Pan Reverse①	Yes/No(No)	
		Tilt Reverse①	Yes/No(No)	
		Feedback①	Yes/No (Yes)	
		Pan/Tilt Mode①	Slow/Medium/Fast (Fast)	
		Totem Mode①	Off/Up/Down(Off)	
	Screen	Backlight①	02~60M (02M)	
		Flip Display①	On/Off(Off)	
		Key Lock①	On/Off (Off)	
	Information	Fixture Time	Fixture Hours	Total
Partial				(Read And Reset)
Current Hours			Total	( Only Read)
			Partial	(Read And Reset)
Lamp Hours			Total	( Only Read)
			Partial	(Read And Reset)
Power On Cycle		Total	( Only Read)	
		Partial	(Read And Reset)	
Temperature		Near Source Temp,Driver PCB Temp,Led PCB Temp,...		
Fans Speed		Near Source Fan,Base Fan ...		
Channel Value		Pan.....		
Error Message		Pan,Tilt.....		
Fixture Model		xxxxxxxxxxxx		
RDM UID		(Read And Reset)		
Software Version		1U01 V1.0.00.....,.		
Service	Reset	All		
		Pan&Tilt		
		:		
	Calibration	Password	=xxx	
		Pan	=xxx	
:		:		

		Focus	=xxx		
		Gobo 1	Focus		
		:	:		
		Gobo 8	Focus		
		:			
		Encoder Reset	clean value in encoder pcb		
	Manual Control	Pan			
		:			
	Reload Default	Basic Reload(①)	On/Off (Off)		
		Factory Reload	On/Off(Off)		
Program	Play①	DMX Receive			
		Slave Receive	Slave Receive 1,2,3		
		Sequence	Master / Alone		
		Music	Master / Alone		
	Select Chase②	Chase Part 1	Chase 1 ~ 8	Chase 1	
		Chase Part 2	Chase 1 ~ 8	Chase 2	
		Chase Part 3	Chase 1 ~ 8	Chase 3	
	Edit Chase②	Chase 1	Chase Test		
		:	Step 01	=xxx	
		Chase 8	Step 64	=xxx	
	Edit Scenes②	Edit Scene 001	Pan,Tilt,.....	=xxx	
		~ Edit Scene 250	--Fade Time--	=xxx	
			--Secne Time--	=xxx	
			DMX Input		
	Scenes Record	ScXX=>ScXX			

## 5. DMX connection and DMX protocol

### 5.1 DMX addressing:

5.1.1 The device is controlled by universal DMX 512 protocol, DMX address is the start channel used to receive instructions from the external controller. For independent control, each fixture must be assigned its unique address control channels. For example, this device has four channel modes:39, if we set the mode at standard 39 channels mode, and there are several models need to be independently controlled, we just simply address first fixture at 1, and second fixture at 40, third one at 79, etc.

If the devices have the same address, they will behave synchronically.

DMX addressing is limited, don't set the address so high that without enough control channels for the fixtures.

Display is flashing when no DMX signal is received.

5.1.2 This device is equipped with 5-pins DMX in and out sockets only.



Pin1=GND      Pin4=N.A.  
Pin2=SIG(-)    Pin5=N.A.  
Pin3=SIG(+)



5.1.3 The termination is prepared by soldering a 120Ω resistor between pins 2 and 3.

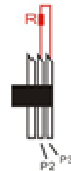
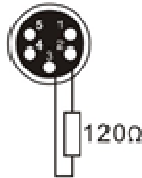

5.1.4 Connection: use DMX cable with 5 pin XLR-plugs to connect the controller with the fixture or one fixture with another.

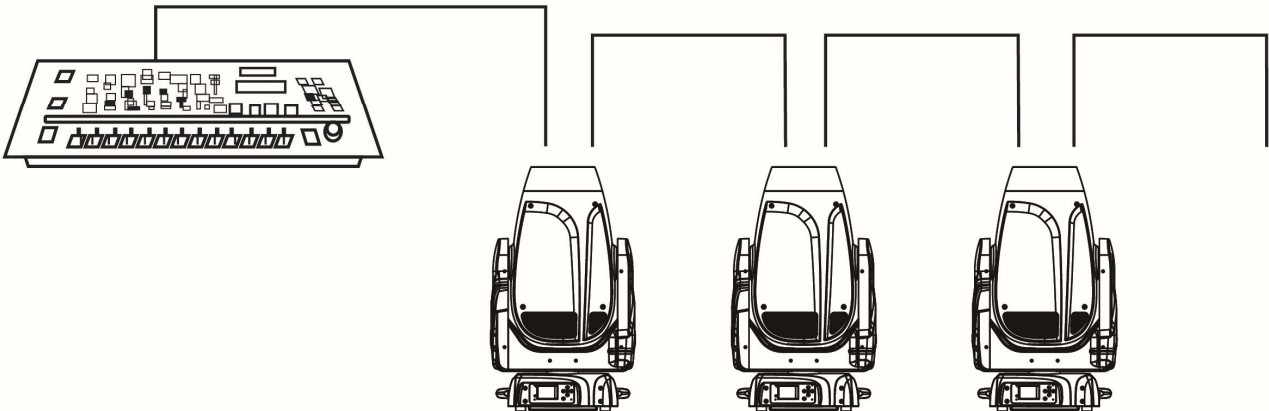

## 5.2 DMX chart

CHANNEL	name	function	Min DMX	Max DMX
STANDARD				
1	Pan	Lineary from 0% to 100%	0	255
2	Pan fine	Lineary from 0% to 100%	0	255
3	Tilt	Lineary from 0% to 100%	0	255
4	Tilt fine	Lineary from 0% to 100%	0	255
5	XY Speed	Fast to Slow	0	255
6	Shutter	Close	0	1
		Strobe from slow to fast	2	62
		Open	63	64
		Pulse in from slow to fast	65	125
		Open	126	127
		Pulse out from slow to fast	128	188
		Open	189	190
		Randon from slow to fast	191	251
	Open	252	255	
7	Dimmer	Lineary from close to open	0	255
8	Dimmer Fine	Lineary from close to open	0	255
9	Cyan	Lineary from 0% to 100%	0	255
10	Magenta	Lineary from 0% to 100%	0	255
11	Yellow	Lineary from 0% to 100%	0	255
12	CTO	Lineary from 0% to 100%	0	255
13	Color Wheel	Indexed		
		Open	0	8
		Open + COLOR 1	9	15
		COLOR 1	16	22
		COLOR 1 + COLOR 2	23	29
		COLOR 2	30	36
		COLOR 2 + COLOR 3	37	43
		COLOR 3	44	50
		COLOR 3 + COLOR 4	51	57
		COLOR 4	58	64
		COLOR 4 + COLOR 5	65	71
		COLOR 5	72	78
		COLOR 5 + COLOR 6	79	85
		COLOR 6	86	92
		COLOR 6 + COLOR 7	93	99
		COLOR 7	100	106
		COLOR 7 +COLOR 8	107	113
		COLOR 8	114	120
		COLOR 8 + Open	121	127
		Forward Spin		
From fast to slow	128	190		
Stop				
Stop	191	192		

		Reverse Spin		
		From slow to fast	193	255
14	Rot Gobo	Indexed		
		Open	0	7
		GOBO 1	8	15
		GOBO 2	16	23
		GOBO 3	24	31
		GOBO 4	32	39
		GOBO 5	40	47
		GOBO 6	48	55
		GOBO 7	56	63
		Forward Spin		
		From fast to slow	64	130
		Stop		
		Stop	131	132
		Reverse Spin		
		From slow to fast	133	199
		Shake		
		GOBO 1 from slow to fast	200	207
		GOBO 2 from slow to fast	208	215
		GOBO 3 from slow to fast	216	223
		GOBO 4 from slow to fast	224	231
		GOBO 5 from slow to fast	232	239
		GOBO 6 from slow to fast	240	247
GOBO 7 from slow to fast	248	255		
15	Gobo Rot	Indexed		
		Lineary from 0° to 360°	0	127
		Forward Spin		
		From fast to slow	128	190
		Stop		
		Stop	191	192
		Reverse Spin		
From slow to fast	193	255		
16	Gobo Rot Fine	Lineary from 0° to 360° (Indexed)	0	255
17	Fixed Gobo	Indexed		
		Open	0	5
		GOBO 1	6	11
		GOBO 2	12	17
		GOBO 3	18	23
		GOBO 4	24	29
		GOBO 5	30	35
		GOBO 6	36	41
		GOBO 7	42	47
		GOBO 8	48	53
		Forward Spin		

		From fast to slow	54	125
		Stop		
		Stop	126	127
		Reverse Spin		
		From slow to fast	128	199
		Shake		
		GOBO 1 from slow to fast	200	205
		GOBO 2 from slow to fast	206	211
		GOBO 3 from slow to fast	212	217
		GOBO 4 from slow to fast	218	223
		GOBO 5 from slow to fast	224	229
		GOBO 6 from slow to fast	230	235
		GOBO 7 from slow to fast	236	241
		GOBO 8 from slow to fast	242	255
18	4f Prism	Open	0	127
		Prism insert	128	255
19	4f Prism Rotation	Indexed		
		Lineary from 0° to 360°	0	127
		Forward Spin		
		From fast to slow	128	190
		Stop		
		Stop	191	192
		Reverse Spin		
		From slow to fast	193	255
20	Frost	Continuous		
		Lineary from 0% to 100%	0	255
21	Zoom	Lineary from in to out	0	255
22	Zoom Fine	Lineary from in to out	0	255
23	Focus	Lineary from in to out	0	255
24	Focus Fine	Lineary from in to out	0	255
25	Animation Insertion	Continuous		
		Lineary from 0% to 100%	0	255
26	Animation Rotation	Indexed		
		Lineary from 0° to 360°	0	127
		Forward Spin		
		From fast to slow	128	190
		Stop		
		Stop	191	192
		Reverse Spin		
		From slow to fast	193	255
27	Iris	Indexed	0	191
		Pulse opening With Forward Backout	192	207
		Pulse opening With Reverse Backout	208	223
		Pulse closing With Forward Backout	224	239
		Pulse closing With Reverse Backout	240	255

28	Blade1 Position	Blade1 Position 0->100%	0	255
29	Blade1 Rot	Blade1 Rot	0	255
30	Blade2 Position	Blade2 Position 0->100%	0	255
31	Blade2 Rot	Blade2 Rot	0	255
32	Blade3 Position	Blade3 Position 0->100%	0	255
33	Blade3 Rot	Blade3 Rot	0	255
34	Blade4 Position	Blade4 Position 0->100%	0	255
35	Blade4 Rot	Blade4 Rot	0	255
36	Blade Rot	Blade All Rotation	0	255
37	Frame macros	No Function	0	3
		Macro 1	4	10
		Macro 2	11	17
		Macro 3	18	24
		Macro 4	25	31
		Macro 5	32	38
		Macro 6	39	45
		Macro 7	46	52
		Macro 8	53	59
		Macro 9	60	66
		Macro 10	67	73
		Macro 11	74	80
		Macro 12	81	87
		Macro 13	88	94
		Macro 14	95	101
		Macro 15	102	108
		Macro 16	109	115
		Macro 17	116	122
		Macro 18	123	129
		Macro 19	130	136
		Macro 20	137	143
		Macro 21	144	150
		Macro 22	151	157
		Macro 23	158	164
		Macro 24	165	171
		Macro 25	172	178
		Macro 26	179	185
		Macro 27	186	192
		Macro 28	193	199
		Macro 29	200	206
		Macro 30	207	213
		Macro 31	214	220
		Macro 32	221	227

		Macro 33	228	234
		Macro 34	235	241
		Macro 35	242	248
		Macro 36	249	255
38	Frame macros speed	Lineary from 0 to 100%	0	255
39	Control	No Function/Safe	0	1
		PAN REVERSE ON	2	3
		PAN REVERSE OFF	4	5
		TILT REVERSE ON	6	7
		TILT REVERSE OFF	8	9
		PAN/TILT MODE FAST	10	11
		PAN/TILT MODE MEDIUM	12	13
		PAN/TILT MODE SLOW	14	15
		HOME MODE STANDARD	16	17
		HOME MODE CUSTOM	18	19
		MOVEMENT IN BLACKOUT ON	20	21
		MOVEMENT IN BLACKOUT OFF	22	23
		COLOR WHEEL BLACKOUT ON (index)	24	25
		COLOR WHEEL BLACKOUT OFF (index)	26	27
		ROTATING GOBO WHEEL BLACKOUT ON (index)	28	29
		ROTATING GOBO WHEEL BLACKOUT OFF (index)	30	31
		FIX GOBO WHEEL BLACKOUT ON (index)	32	33
		FIX GOBO WHEEL BLACKOUT OFF (index)	34	35
		DISPLAY ON	36	37
		DISPLAY 10S	38	39
		DISPLAY 20S	40	41
		DISPLAY 30S	42	43
		FLIP DISPLAY ON	44	45
		FLIP DISPLAY OFF	46	47
		FLIP DISPLAY AUTO	48	49
		KEY LOCK ON	50	51
		KEY LOCK OFF	52	53
		FAN MODE AUTO	54	55
		FAN MODE SILENT	56	57
		FAN MODE HIGH	58	59
NO SIGNAL HOLD	60	61		
NO SIGNAL BLACKOUT	62	63		
STATUS LED ON	64	65		
STATUS LED OFF	66	67		
DIMMER CURVE LINEAR	68	69		
DIMMER CURVE S-CURVE	70	71		
DIMMER CURVE SQUARE LAW	72	73		
DIMMER CURVE INVERSE SQUARE LAW	74	75		
DIMMER SPEED AUTO	76	77		

DIMMER SPEED FAST	78	79
DIMMER SPEED MEDIUM	80	81
DIMMER SPEED SLOW	82	83
LED FREQUENCY 600HZ	84	85
LED FREQUENCY 1200HZ	86	87
LED FREQUENCY 2000HZ	88	89
LED FREQUENCY 4000HZ	90	91
LED FREQUENCY 6000HZ	92	93
LED FREQUENCY 25KHZ	94	95
LED FREQUENCY 50KHZ	96	97
INVERT ZOOM OFF	98	99
INVERT ZOOM ON	100	101
RESET ALL	102	103
RESET PAN	104	105
RESET TILT	106	107
RESET PAN & TILT	108	109
RESET CYAN	110	111
RESET MAGENTA	112	113
RESET YELLOW	114	115
RESET CTO	116	117
RESET COLOR WHEEL	118	119
RESET GOBO WHEEL	120	121
RESET GOBO ROTATION	122	123
RESET FIX GOBO WHEEL	124	125
RESET ANIMATION	126	127
RESET ANIMATION ROTATION	128	129
RESET PRISM	130	131
RESET PRISM ROTATION	132	133
RESET FROST	134	135
RESET IRIS	136	137
RESET ZOOM	138	139
RESET FOCUS	140	141
RESET FRAME ROT	142	143
RESET BLADE 1 POSITON	144	145
RESET BLADE 1 ROT	146	147
RESET BLADE 2 POSITON	148	149
RESET BLADE 2 ROT	150	151
RESET BLADE 3 POSITON	152	153
RESET BLADE 3 ROT	154	155
RESET BLADE 4 POSITON	156	157
RESET BLADE 4 ROT	158	159
Reserved	160~253	
FACTORY DEFAULT OF CONTROL FUNCTIONS	254	255

## 6.Unique Features

6.1 RDM, stand for “Remote Device Management”, with this function, users can realize remote control of the device, such as remotely changing DMX address, reverse pan/tilt setting, check a lot of useful information such as temperature, power consumption, fan speed. Etc. Every single device has a unique RDM code before left factory to distinguish from each other, usually not suggest users change this code freely.

6.2 Software upgrade function via DMX cable, if there is any new firmware for this device come out, it can be upgraded simply via a software upgrade box, no need to change any mechanical parts. The upgrade box is not included in the package, if need any further assistance pls just contact authorized dealers.

6.3 Hibernation, the device will enter sleeping mode if activated after a period of disconnecting DMX signal to save the power consumption, and will return immediately as soon as the DMX signal is sent again.

6.4 Display flip, by press up and down button for more than 3 seconds, the display will flip automatically, this function is useful to read menu conveniently when device is hanged.

## 7. Dimensions Drawing

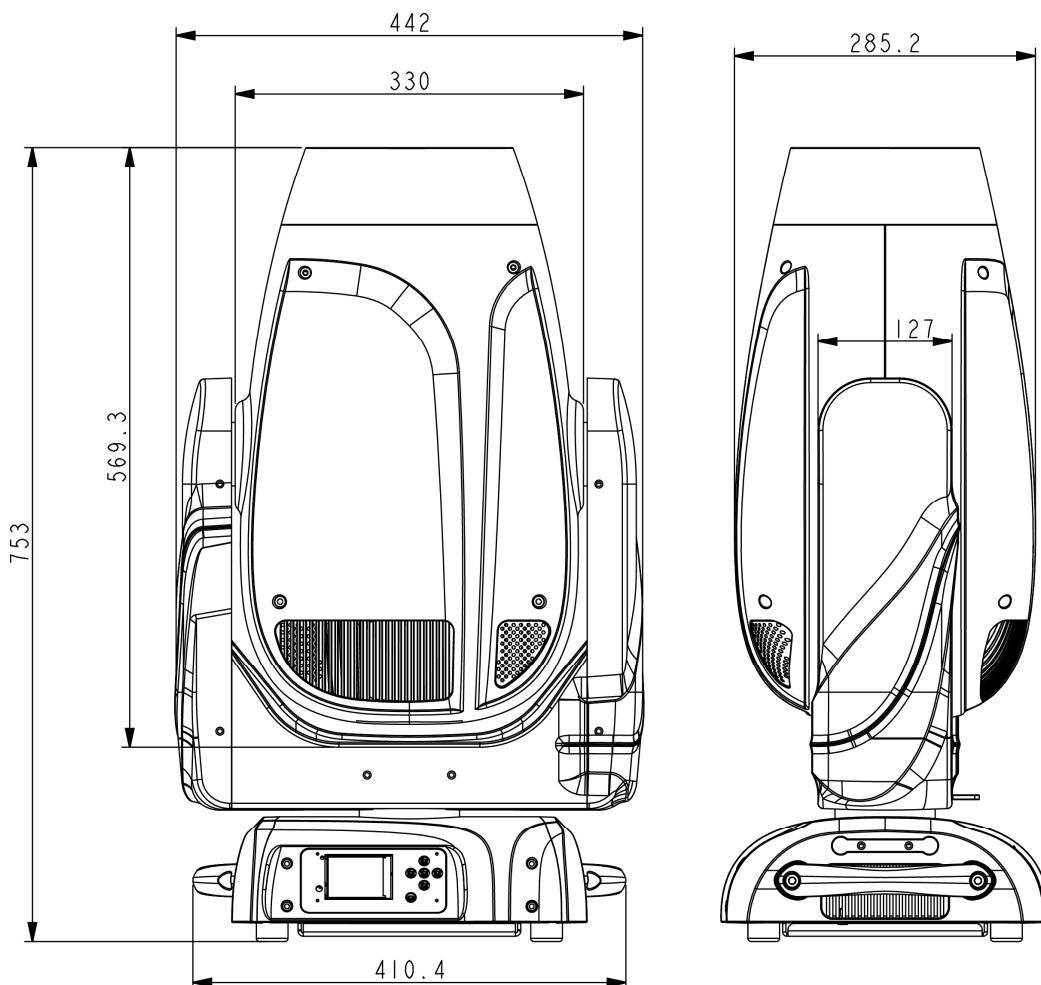

## 8. Technical specification

Power supply	100-240 V AC , 50/60 Hz ~
Power consumption	866W
Lamp	Advanced 640w white led
DMX channels	39 channels
Beam angle	4° to 50 °
Luminous flux	83800 lux@5m
Fuse	T10A , 250 V
Device dimensions	748x443x305mm
Net Weight	35.1KG
Gross Weight	40.7KG
IP	20